



ICC INDUSTRIAL CHIMNEY COMPANY INC.
ST-JEROME, QUÉBEC, CANADA, J7Y 4B7
TEL: (450) 565-6336 • FAX: (450)565-6519

INSTALLATION AND OPERATION INSTRUCTIONS

"RIS"

CHIMNEY TYPE: Type "A" factory-built chimney suitable for venting negative or neutral draft (non-pressurized) appliances including boilers, building heating equipment, fireplaces and stoves. RIS has been designed, tested, and listed to vent large wood burning fireplaces and to extend masonry chimneys. RIS is listed to the UL 103HT standard for use in the USA. **Note for customers in Canada:** Model RIS is not certified to the ULC S-629 Standard.

SIZE: 6" - 24" Chimney

A MAJOR CAUSE OF CHIMNEY RELATED FIRES IS FAILURE TO MAINTAIN REQUIRED CLEARANCE (AIR SPACE) TO COMBUSTIBLE MATERIALS. IT IS OF UTMOST IMPORTANCE THAT THIS CHIMNEY BE INSTALLED ONLY IN ACCORDANCE WITH THESE INSTRUCTIONS.

Use only factory supplied components. Failure to do so will void the certification and the warranty of this chimney.

If possible, install the chimney on the interior of the building as it will provide better performance than an exterior chimney. In areas with continuous temperatures below 0°F the use of an exterior chimney may result in operating problems such as poor draft and excessive condensation of combustion products. If you do install an exterior chimney, we recommend that you install it within an insulated enclosure.

Read these instructions and keep them for future reference. Contact local building or fire officials about restrictions and installation inspection in your area.

RIS has been tested and listed to the UL 103HT chimney standard by Warnock Hersey - Intertek Testing Services
Listing # 50195-C7-704800



Contents

TECHNICAL SPECIFICATIONS	3
Materials.....	3
Allowable Flue Gas Temperatures.....	3
Clearances.....	3
RIS DIMENSIONS AND CAPACITIES	4
GENERAL INSTALLATION NOTES	5
Chimney Cleaning.....	5
Chimney Sizing.....	5
Recommended Flue Height.....	6
Earthquake Damaged Chimneys.....	7
Local Requirements.....	7
INSTALLATION INSTRUCTIONS	7
Chimney Lengths.....	7
Adjustable Length.....	7
Anchor Plate.....	8
Boiler Applications.....	8
Using an anchor plate to extend an existing masonry chimney.....	8
CHIMNEY EXTENSIONS	9
TYPICAL SITE BUILT	9
Extending a masonry chimney lined with a metal chimney liner.....	10
Masonry Transitions.....	10
Fireplace Applications.....	10
RIS Minimum Rough Opening Dimensions.....	11
Floor or Base Support.....	11
Wall Support.....	11
Through the Wall Installation - Wall Support and Wall Radiation Shield.....	12
Round and Square Support.....	13
Attic and Roof Area.....	13
Elbows.....	14
Wall Band.....	14
Guy Band.....	14
Radiation Shield.....	15
Rain Caps.....	15
After market chimney top devices.....	15
PART DESCRIPTIONS	16 to 18
RIS OFFSET TABLES	19
WARRANTY	20

TECHNICAL SPECIFICATIONS

MATERIALS:

CASING: Standard: Type 304 Stainless Steel
Optional: Galvalume, Type 430, 444 or 316 Stainless

FLUE: Standard: Type 304 Stainless Steel
Optional: Type 444 or 316 Stainless Steel

INSULATION: "THERMOPLUS" HIGH TEMPERATURE MINERAL FIBRE

SIZE: 6" TO 24" Inside Diameter

ALLOWABLE FLUE GAS TEMPERATURES:

Maximum Continuous: 1000°F

Brief Forced Firing: 1400°F

Tested To: (3 X 10 min.) 2100°F

CLEARANCES: To Combustible Materials: 2" Air Space Minimum
To Non-Combustible Materials: No Clearance Required

NOTE: NFPA 211 requires that all chimneys used on solid fuel residential applications to be listed to UL 103HT

RIS DIMENSIONS AND CAPACITIES

RIS Minimum Rough Opening Dimensions												
Diameter		6	7	8	10	12	14	16	18	20	22	24
Hole Size (in.)	Combustible Wall, Floor or Roof	12	13	14	16	18	20	22	24	26	28	30
	Non-Combustible Wall, Floor or Roof	9	10	11	13	15	17	19	21	23	25	27

RIS Vertical capacity Table											
Size	6"	7"	8"	10"	12"	14"	16"	18"	20"	22"	24"
Anchor Plate	186'	166'	146'	120'	102'	89'	78'	70'	64'	58'	53'
Floor Support	186'	166'	146'	120'	102'	89'	78'	70'	64'	58'	53'
Wall Support	150'	130'	118'	97'	82'	72'	63'	57'	51'	47'	43'
Offset Support	55'	50'	45'	40'	35'	30'	25'	20'	20'	20'	20'
Roof Support	55'	50'	45'	40'	35'	30'	25'	20'	20'	20'	20'
Insulated Tee	65'	61'	57'	53'	45'	39'	35'	31'	28'	26'	23'
Chimney Length	186'	166'	146'	120'	102'	89'	78'	70'	64'	58'	53'
Adjustable Length											

RIS Chimney Dimensions		
Diameter	OD	lbs/ft.
6"	8¼"	3.8
7"	9¼"	4.4
8"	10¼"	4.8
10"	12¼"	5.9
12"	14¼"	6.9
14"	16¼"	7.9
16"	18¼"	9
18"	20¼"	13
20"	22¼"	14.3
22"	24¼"	15.7
24"	26¼"	17

Nominal Length	Installed Length
48"	46¼"
24"	22¼"
24" adjustable	13½" - 24"
12"	10¼"
12" adjustable	7½" - 12"

GENERAL INSTALLATION NOTES

1. The chimney is intended for use with residential, commercial and industrial heating appliances, and for fireplaces where permitted by the local building codes. See page 3 for maximum allowable flue gas temperatures.
2. Size the chimney in accordance with the appliance manufacturer's instructions. For masonry fireplaces follow TABLE 1. When extending a masonry chimney the cross sectional area of the RIS chimney must equal or slightly exceed the cross sectional area of the existing chimney. Note: In the chart on page 4 the chimney size is a function of fireplace opening size, it is possible to change the chimney diameter required by increasing or reducing the opening size.
3. The chimney may be enclosed in a combustible chase. If it is desirable to enclose the chimney, then maintain at least 2" clearance to combustibles. We recommend that the chase be lined with gyprock. Some areas require type X gyprock, see local authorities for the regulations in your area.
4. Do not fill the space around the chimney with insulation or any other material. This space must remain empty.
5. The chimney shall extend at least 3 ft. above its point of contact with the roof and at least 2 ft. higher than any wall, roof or adjacent building within 10 ft. The chimney must project a minimum of 8" above a locally fabricated metal chase flashing. Note: In California this chase flashing is required to be ventilated.
6. The maximum height of un-braced or un-guyed chimney above the roof is 5 ft.
7. The clearance between single wall stove pipe and unprotected combustible material must not be less than 18" (refer to the Building Code in use in your area).
8. Factory built chimneys which extend through any story above that on which the connected appliance is located are to be provided with enclosures having a fire rating equal to or greater than that of the floor or roof assembly through which they pass.
9. A support must be installed above each chimney offset. See table 4 for load ratings.
10. We recommend that an existing masonry chimney be inspected and cleaned by a qualified chimney sweep prior to commencing the installation of a chimney extension or chimney lining.

CHIMNEY CLEANING

Keep your chimney clean. Access should be provided for the inspection and cleaning of all sections of the chimney. Have your chimney cleaned by a qualified chimney sweep. If you want to clean your chimney yourself, then clean your chimney using a nylon or metal chimney brush of the CORRECT SIZE. DO NOT use a brush that will scratch the stainless steel interior of the chimney.

Soot Formation and Need for Removal (oil appliance):

Soot can accumulate on the chimney flue when connected to an oil fired appliance. If not removed periodically this deposit can ignite and cause possible damage to the chimney. The chimney should be inspected at least once every year during the heating season to determine if a soot build up has occurred. If soot has accumulated, it should be removed to reduce the risk of chimney fire.

CHIMNEY SIZING

Use the table on page 6 to determine the correct diameter of chimney for an open masonry fireplace. For factory-built fireplaces and wood-burning stoves, use the size specified by the appliance manufacturer. In most cases, this is the diameter of the flue collar.

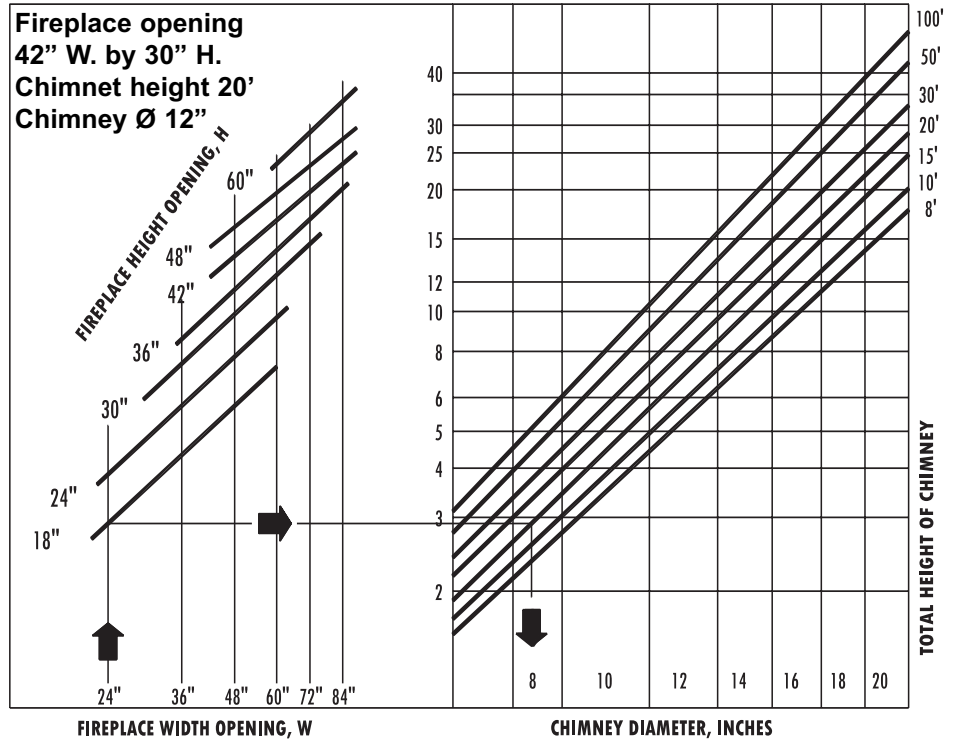
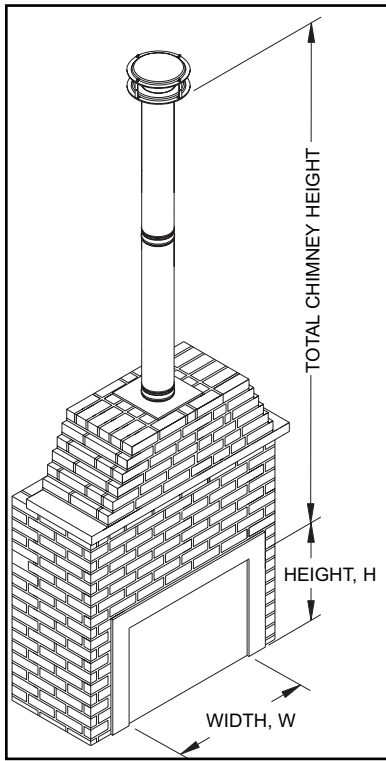

RECOMMENDED FLUE HEIGHT

Once the correct chimney size has been determined, there are two factors which can be compensated for when calculating the optimum height of the system - elevation and chimney layout. The higher the elevation, the greater the chimney height required to provide the same draft as an installation a sea level. The more complex the chimney layout (the more tees, elbows, etc. in the system) the greater the chimney height required to provide the same draft as a straight up system. The table on the right suggests the minimum height required to insure adequate draft under a variety of conditions.

Minimum Recommended Flue Height from the flue connection on the appliance (feet)										
Elevation Above Sea Level (feet)	Number of elbows								1.	2.
	0	2 X 15°	2 X 30°	2 X 45°	4 X 15°	4 X 30°	4 X 45°			
0-1000	12	13	15	16	14	18	20	18	20	
1000-2000	12 ½	13 ½	15 ½	16 ½	14 ½	19	20 ½	19	21	
2000-3000	13	14	16	17	15	19 ½	21 ½	19 ½	21 ½	
3000-4000	13 ½	14 ½	17	18	15 ½	20	22 ½	20	22 ½	
4000-5000	14	15	17 ½	18 ½	16	21	23	21	23	
5000-6000	14 ½	15 ½	18	19	17	21 ½	24	21 ½	24	
6000-7000	15	16	18 ½	20	17 ½	22 ½	25	22 ½	25	
7000-8000	15 ½	16 ½	19	20 ½	18	23	25 ½	23	25 ½	
8000-9000	16	17	20	21	18 ½	24	26 ½	24	26 ½	
9000-10000	16 ½	17 ½	20 ½	22	19	24 ½	27	24 ½	27	

No more than two offsets (four elbows) allowed

1. This column shows the height required for a rear vented stove run 18" horizontally into a tee

2. This column shows the height required for a top vented stove with a 90° degree elbow and an 18" horizontal run into a tee

EARTHQUAKE DAMAGED CHIMNEYS

When using an RIS chimney to repair a damaged masonry chimney it is important to note that ICC is not in a position to determine the condition of the existing masonry. The assessment of the existing structure and determination of the correct repair procedure is beyond the scope of these instructions. In some cases a proper damage assessment will require an on site evaluation by a professional engineer. **Because of the uncertainty related to the existing structure earthquake damage repairs should only be completed by knowledgeable, experienced contractors.**

RIS chimneys have been specifically designed, tested and listed to vent masonry fireplaces in residential installations and to extend existing masonry chimneys. One of the primary applications of RIS is for the repair of earthquake damaged masonry fireplaces and chimneys. ICC provides components designed to correctly adapt our products to existing masonry construction and we warranty the performance and mechanical integrity of our system **when it is correctly installed on a structurally sound foundation.**

LOCAL REQUIREMENTS

The requirements for chimney repair vary substantially from jurisdiction to jurisdiction. We strongly recommend that you contact your local building officials to determine the requirements in your particular area before attempting any chimney repairs. Some municipalities (e.g.: The City Of Los Angeles) have specific written repair requirements - most other areas are not as specific. Two sources of information concerning the construction and inspection of masonry chimneys and fireplaces are "The Residential Fireplace and Chimney Handbook" written by the Masonry Institute of America and "Repair Of Earthquake Damaged Masonry Chimneys Using New Metal Chimneys" by the City of Los Angeles Department of Building and Safety.

INSTALLATION INSTRUCTIONS

CHIMNEY LENGTHS (RIL)

Install chimney lengths as follows:

1. Stack one chimney length on to another.
2. Screw the stainless steel metal screws supplied with the length through the pre-punched holes in the bottom of the length and into the lower length. Be sure to use a metal screw in each pre-punched hole. Continue until the required chimney height is achieved.
3. In some installations it is difficult to install all of the screws in the pre-punched holes (eg: when the chimney is run parallel to a wall at minimum clearance). In these installations it is possible to install a locking band however the use of a locking band does not totally eliminate the requirement for screws. You should install as many screws as possible (the screws do not all need to be in the pre-punched holes) and you must install at least half of the screws.

ADJUSTABLE LENGTH (RILA)

The adjustable length is to allow the chimney to fit in a fixed distance when a suitable standard length is not available. Typical applications are between two elbows when a fixed offset distance is required or between two boiler outlet flanges which are a fixed distance apart.

The length of the outer casing of the adjustable length must be set before it is installed. The adjustable length is installed by sliding the flue (inner stainless steel) into the section below it after the two piece outer casing has been adjusted to the correct overall length. The adjustable length should be installed with a straight chimney section below it, there is not sufficient room for it to adjust into a tee or elbow.

1. Measure the exact length required, be sure to allow for the overlap between chimney sections.
2. Slide the two piece outer casing together until the correct overall length is achieved.

3. Fasten the two casing sections together using the stainless steel metal screws provided. Be sure to put a screw in each pre-punched hole.
4. Cut off the exposed insulation. You do not need to remove any extra insulation in order to allow for overlap, the insulation will compress sufficiently when assembled.
5. Slide the flue into the length below it and fasten the exterior together in the same manner as a conventional chimney section. It may require somewhat more effort to connect the adjustable length since you are compressing the insulation at the same time.

ANCHOR PLATE (AP)

Boiler Applications

The chimney may be supported directly on top of the appliance. This is achieved by attaching an Anchor Plate (AP) directly to the outlet of the appliance.

The maximum height of chimney supported will be determined by the allowable maximum load on the boiler, but should generally not exceed 25 feet.

1. The support should be bolted to the appliance using 3/8" or larger bolts.
2. Place the first chimney length in the anchor plate. Fasten it in place using one factory supplied stainless steel screw through each anchor plate bracket into the chimney casing.

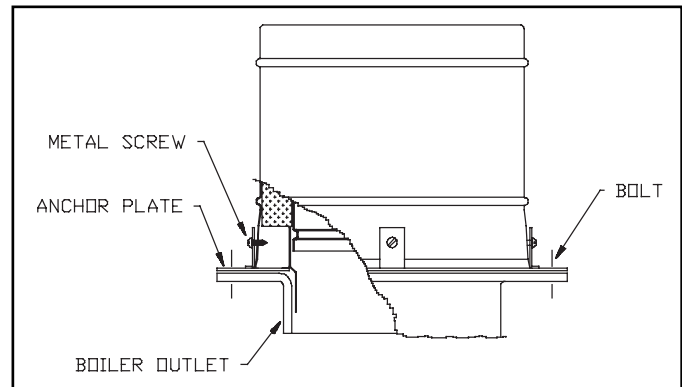

Using an anchor plate to extend an existing masonry chimney.

There are two common applications for extending a masonry chimney with an RIS chimney - when the masonry chimney is too short causing draft problems and when the masonry chimney is damaged as a result of age or mechanical shock (earthquake).

1. If the RIS chimney is being used to extend an existing chimney in good condition then the anchor plate may be installed directly on to the existing chimney. It is often necessary to remove a portion of the top liner and some of the masonry cap in order to achieve a structurally sound clean, flat surface. Alternatively a concrete bond beam may be poured on top of the existing masonry in order to achieve a flat surface. In either case read the section on masonry transitions carefully before installing the anchor plate (see page 10).
- 1A. If the RIS chimney is being used to extend a damaged chimney read the information on page 7 regarding repairs of earthquake damaged chimneys carefully. There is no substitute for a thorough on site examination of the existing chimney by a qualified contractor. The pamphlet "Repair Of Earthquake Damaged Masonry Chimneys Using New Metal Chimneys" by the City of Los Angeles Department of Building and Safety provides specific instructions on how to determine a suitable location to adapt from masonry to metal. This pamphlet also recommends specific steel bracing which must be fastened to the roof to provide lateral support for the existing masonry. See drawings of typical installations on page 9.
2. Pour a concrete bond beam to provide a suitable surface to fasten the anchor plate and seal the top of the existing masonry. Read the section on masonry transitions carefully before installing the a bond beam or anchor plate (see page 10).
3. Apply silicone to the top surface of the masonry prior to bolting the anchor plate down.
4. Bolt the anchor plate to the top of the existing masonry using 3/8" or larger metal anchors solidly fastened into the existing masonry.
5. Screw the first section of chimney to the anchor plate using one factory supplied stainless steel screw through each pre-punched hole.

6. Carefully caulk the bottom of the chimney section with silicone where it contacts the anchor plate to prevent water from entering between the anchor plate and the chimney. At the same time insure that the perimeter of the anchor plate is thoroughly caulked where it contacts the masonry.
7. Install additional components as required. Be sure to maintain the required clearance to combustible materials.
8. The maximum height of un-braced or un-guyed chimney above a roof is 5 ft.
9. The maximum height above an anchor plate without a lateral support is 5'.

TYPICAL MASONRY CHIMNEY EXTENSIONS

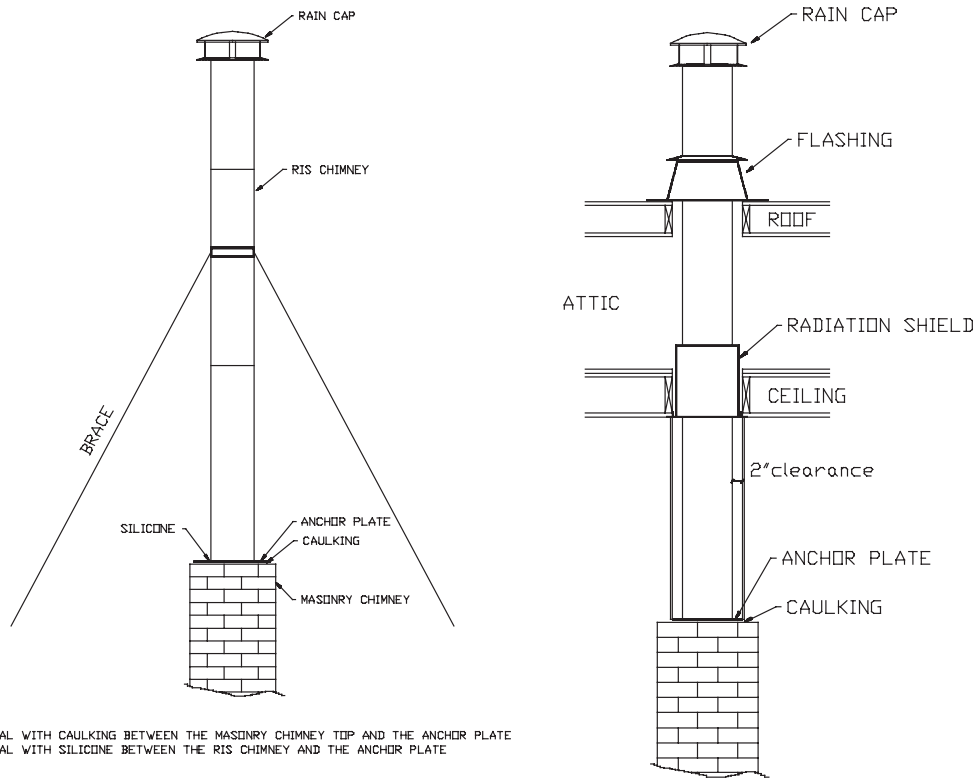

TYPICAL SITE BUILT TRANSITION

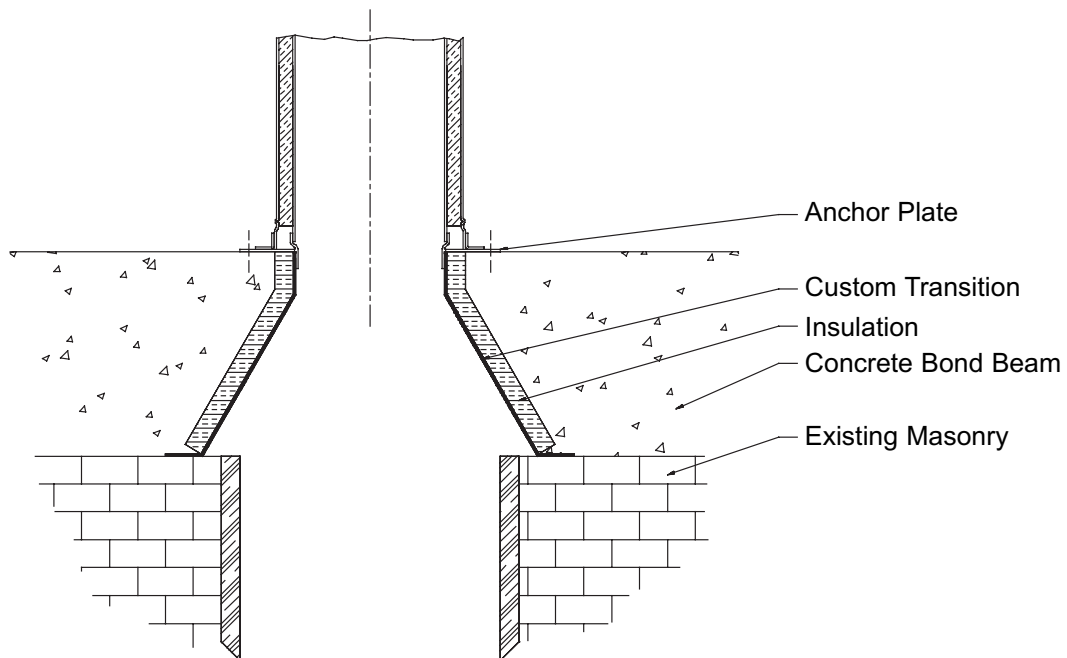

Extending a masonry chimney lined with a metal chimney liner

RIS may be used to extend a masonry chimney which has been lined with an approved chimney liner. This type of repair is generally found where the original flue tile has been damaged by chimney fire or moisture and in cases where the flue has been relined to reduce its cross section. The RIS anchor plate has a single wall connector section designed to allow a metal chimney liner to be screwed directly to it.

Masonry Transitions

Masonry flue liners are typically rectangular, oval, or square, and they are rarely consistent in size. When installing an RIS chimney to extend a clay tile liner the new round chimney must have a cross sectional area equivalent to the original masonry flue. In some cases this requires a dramatic change in the shape of the flue (e.g: a 6 X 12 flue adapted to 10" round).

When the original clay tile liner being extended is close to the same size and shape as the RIS chimney it is generally sufficient to construct a smooth, hand laid, refractory cement transition.

When the original clay tile liner is substantially different in size or shape from the RIS chimney it is recommended to install a locally fabricated stainless steel transition section between the two systems in order to insure smooth gas flow. It is not possible for ICC to offer transition sections as a stock item because of the variations in flue tile size - even a "standard size" flue tile varies quite a bit from piece to piece. We recommend that this transition be locally constructed using the following procedure (see the drawing on page 9).

- Make a paper template of the existing tile liner
- Have a local sheet metal fabricator make a rectangular to round tapered transition having the following properties:
- Constructed of .025 (22 gauge) or heavier type 304 or 316 stainless steel
- The rectangular section should correspond as closely as possible to the shape of the template and should have a 1" flare at the end to allow it to seat squarely on top of the existing chimney - **see drawing**.
- The single wall connector on the RIS anchor plate should fit snugly inside the round section of the transition.
- For radical shape changes the tapered section should be 6-8 inches long - this will require a thicker bond beam.

The transition section should be wrapped with 1" of mineral fibre insulation prior to pouring the bond beam. This allows for expansion and contraction and creates a thermal break between the metal and masonry.

FIREPLACE APPLICATIONS

The anchor plate is designed to adapt an RIS chimney to a masonry fireplace.

1. The anchor plate must be installed on a smooth, structurally sound, flat surface.
2. Bolt the anchor plate to the top of the existing masonry using 3/8" or larger metal anchors solidly fastened into the existing masonry. Use the holes in the anchor plate as a template to locate the anchors.
3. Place a bed of refractory cement on the masonry in the area the anchor plate will be in contact with.
4. Bolt the anchor plate down firmly. Allow the refractory cement to dry.

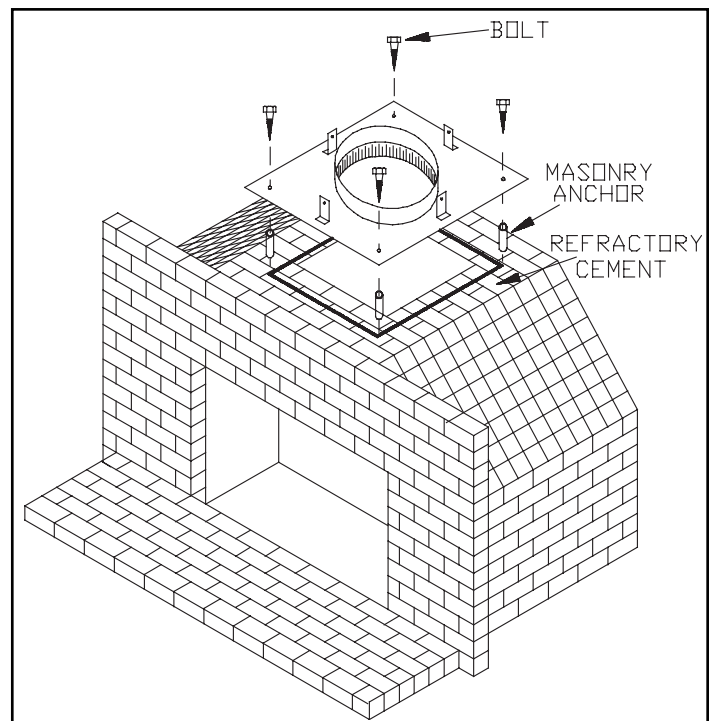

RIS Minimum Rough Opening Dimensions												
Diameter		6	7	8	10	12	14	16	18	20	22	24
Hole Size (in.)	Combustible Wall, Floor or Roof	12	13	14	16	18	20	22	24	26	28	30
	Non-Combustible Wall, Floor or Roof	9	10	11	13	15	17	19	21	23	25	27

FLOOR or BASE SUPPORT (BS)

1. Cut and frame the opening to the dimensions required in table 3 above.
2. Attach the support to the floor using one #10 X 2" screw through each hole in the support.
3. Place the support collar around the chimney length at the desired height. Tighten the ring and then screw the Stainless Steel metal screws (supplied with support) through the collar and into the chimney casing. Be sure to use a metal screw in each pre-punched hole.
4. Place the chimney and collar in the support.
5. Continue installing chimney lengths as required.

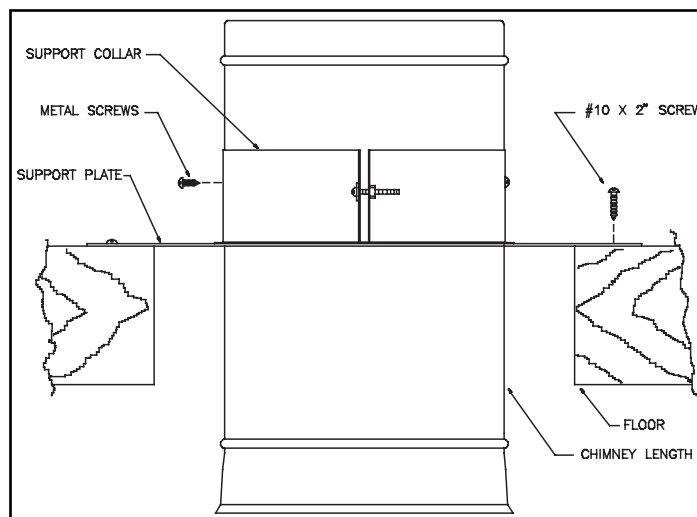

WALL SUPPORT

This support may be attached to a combustible or non-combustible wall. It may be used to support an Insulated Tee or may be used as a re-support fastened to a chimney length.

1. Attach the main support plate to the wall using at least a #10 X 3" screw through each hole in the plate. Make sure the support is horizontal, then attach the angle arms to the wall above the support.
2. Place the support collar around the chimney length at the desired height. Tighten the ring and then screw the Stainless Steel metal screws (supplied with support) through the collar and into the chimney casing. Be sure to use as many metal screws as there are pre-punched holes in the chimney lengths.
3. Place the chimney and collar in the support.
4. Continue installing chimney lengths as required.

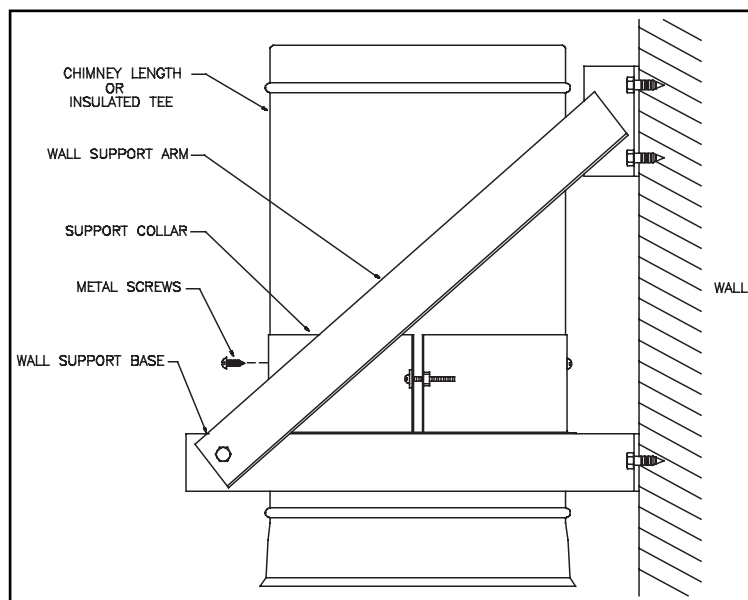

If possible install an interior chimney as it will provide better performance than an exterior chimney. In area with continuous temperatures below 18 C (0°F) the use of an exterior chimney may result in operating problems such as poor draft, excessive condensation of combustion products and rapid accumulation of creosote when connected to a wood burning appliance. If you do install an exterior chimney, we recommend that you enclose it using an insulated enclosure.

NOTES:

1. The chimney may be enclosed or un-enclosed. Maintain 2" clearance to combustible materials. Do not fill the 2" space around the chimney with insulation or any other material.
2. A wall band must be used to secure the chimney to the wall. Maximum distance between wall bands is 8 feet.
3. The minimum horizontal length of chimney extending past the inside wall is 4 inches.
4. The distance between the stovepipe and a parallel combustible wall or ceiling must not be less than 18". The distance between the horizontal stove pipe and the un-shielded vertical wall through which the insulated chimney passes is determined by the Wall Radiation Shield.
5. If an exterior installation is to be enclosed, allow for access to base of Tee to facilitate required cleaning.
6. The minimum distance between the bottom of the chimney and any horizontal combustible surface is 12".

Through the Wall Installation - Wall Support and Wall Radiation Shield

1. Determine where the chimney will pass through the wall.
For concrete walls cut a hole slightly larger than the chimney.
For combustible walls cut and frame a hole (See TABLE 3 for size)
2. Combustible wall:

From outside, put the exterior portion of the wall radiation shield in the hole. Nail the radiation shield in place using 4, 2" nails or # 8 * 1 1/2" wood screws.
3. Fasten the Wall Support to the outside wall. The Wall Support must be adjusted so that the clearance to a combustible wall is at least 2".
4. Stack the next chimney length in place. Fasten the lengths together using one stainless steel metal screw in each pre-punched hole. Continue until the required chimney height is installed.
5. Install a Wall Band at 8' intervals. The Wall Band should be adjusted to ensure the chimney is vertical and at 2" (or more) clearance to combustibles.
6. If the chimney extends above the roof more than 5' above the last lateral brace, it should be secured to the roof using a Roof Brace (RB).
7. Fit the rain cap to the top of the chimney. Screw the metal screws provided through the straps and into the top chimney length.

FROM INSIDE

8. Fasten the flue extension to the horizontal chimney length sticking into the room.
9. Put the interior portion of the wall radiation shield (WRS) in the hole in the wall and push it until it stops against the wall. Fasten it to the wall.

NOTE:

If the chimney passes through the roof, cut a hole large enough to provide 2" clearance between the chimney and the roof. See the table on page 11 for the size. Put the roof flashing in place. Seal the joint between the roof and the flashing with roofing pitch. For sloping roofs, place the flashing under the upper shingles and on top of the lower shingles. Nail the flashing to the roof using roofing nails. Place the storm collar over the chimney and push down until the collar contacts the spacer. Caulk the joint between the chimney and collar with silicone caulking.

ROUND SUPPORT (RDS) & SQUARE SUPPORT (SQS)

Typical round and square support installations are shown in drawings 1 thru 4 on page 13.

The clearance between the chimney and combustible material must not be less than 2" except in areas directly shielded by the support. See the rough opening TABLE 3 for the minimum frame dimensions. Do not fill this area with insulation.

If the support is installed in a ceiling with an attic directly above, the support also acts as the attic radiation shield.

1. Locate the chimney in a convenient place as near as possible to the appliance outlet. Cut and frame the holes in the floor, ceiling, and roof where the chimney will pass.
2. From below, push the support into the framed hole. The support must protrude at least 4" below the finished ceiling. Nail the support to the framed joist using 8 3" spiral nails or # 10 X 2 " wood screws. Place the Finish Collar around the support and fasten it to the ceiling using the two screws provided.
3. Attach the flue extension (found in the support box) to the bottom of the first chimney length using the 3 metal screws provided. Put this chimney length in the support. Push it down firmly in place.
4. From below, install a firestop radiation shield in each floor through which the chimney passes.
5. Stack the next chimney length on the first length. Fasten the three screws supplied through the holes to fasten the chimney together. Continue until the required chimney height is reached.

ATTIC AND ROOF AREA

6. At the attic level, install a radiation shield (RS) from below. With the addition of a storm collar to close the top this shield acts as the joist and the attic radiation shield.

If your chimney is enclosed in the attic proceed as follows:

7. Put the roof flashing in place. Seal the joint between the roof and the flashing with roofing tar. For sloping roofs, place the flashing under the upper shingles and the on top of the lower shingles.
8. Nail the flashing to the roof using roofing nails. Place the storm collar over the chimney and the flashing. Tighten it in place. Caulk the joint between the chimney and storm collar.
9. Fit the rain cap to the top of the chimney. Screw the two metal screws provided through the straps and into the top chimney length.

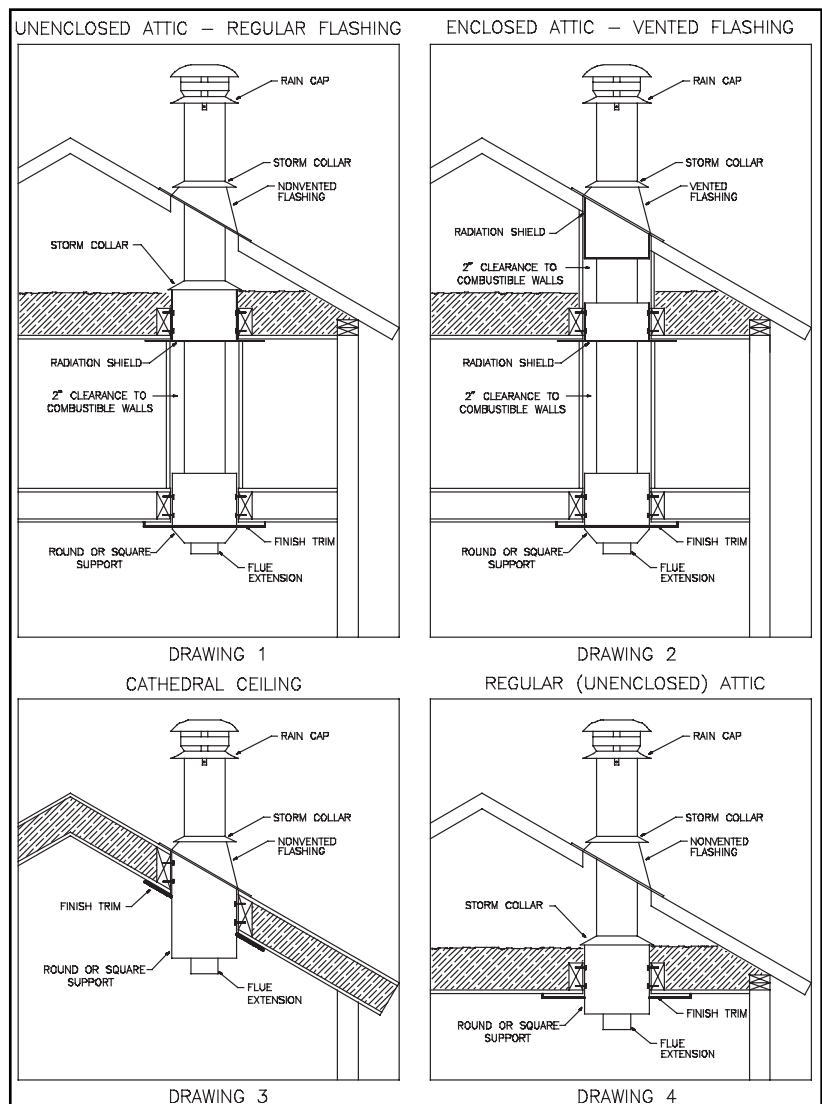

ELBOWS (RIE15, RIE30, & RIE45)

Elbows are used to offset the chimney in order to bypass a building obstruction. Two pairs of 15, 30 or 45 degree elbows (4 elbows total) are allowed per chimney system. There is no limit on the length of chimney between offsets however the chimney must be re-supported at regular intervals - see TABLE 4 for support capacities. Note: 45° elbows are approved for use in Canada only. The elbows are attached in the same manner as the chimney lengths.

See the offset TABLE 7 and TABLE 8 on page 19 for offset dimensions.

1. Place the elbow on the chimney length.
2. Screw the Stainless Steel metal screws (supplied with the elbow) through the pre-punched holes in the bottom of the elbow and into the lower length. Be sure to use a metal screw in each pre-punched hole. The holes in the elbow will not line up with the holes in the chimney section.
3. Install a re-support (a wall support, offset support or roof support) above the return elbow.

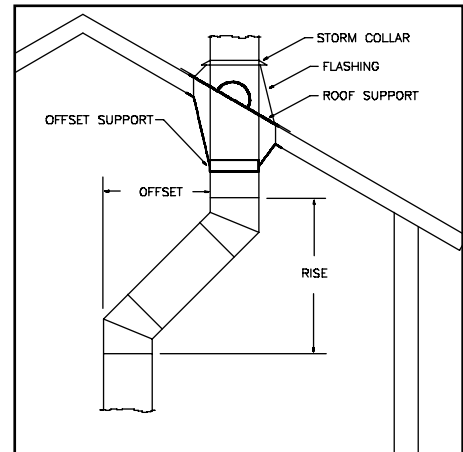

WALL BAND (RWB)

The Wall Band is used to secure the chimney to an exterior or interior wall. The recommended maximum length of chimney between wall bands is eight feet.

1. Choose a convenient location for the Wall Band.
2. Place the band collar around the chimney length at the desired height.
3. Attach the band arms to the collar using the bolts supplied.
4. Attach the band arms to the wall a minimum of #10 X 2" screws through each hole in the support.
5. Tighten the ring and then screw the Stainless Steel metal screws (supplied with wall band) through the collar and into the chimney casing. Be sure to use a metal screw in each pre-punched hole.
6. Adjust the wall support so that the chimney is at least 2" from combustible materials.

GUY BAND (RGB)

The Guy Band is generally used to secure a chimney above the roof. The maximum length of un-guyed chimney above the roof is five feet. The maximum length of guyed chimney above the roof is twenty feet. The maximum length of chimney between guy bands is ten feet. If height greater than ten feet is required above the roof, an engineered support system should be installed.

1. Place the band collar around the chimney length at the desired location. Tighten the ring and then screw the Stainless Steel metal screws (supplied with the band) through the band and into the chimney casing. Be sure to use a metal screw in each pre-punched hole.
2. Attach guy wires to the band and to the roof or ceiling using adequate attachments (not supplied). Install the three guy wires at 120° intervals and tighten them evenly until the chimney is properly located and secure.

RADIATION SHIELD (RRS)

The Radiation Shield is used to shield the chimney when passing through a combustible floor or roof. The See TABLE 3 for the correct rough opening size.

1. Install the length of chimney that passes through the floor or roof.
2. From below place the radiation shield in the floor or roof.
3. Attach it to the floor or roof using # 8 X 2" screws through each pre-punched hole.

RAIN CAP (RRC & RDRC)

All RIS chimneys must be terminated using a rain cap. The RIS design leaves the insulation exposed at the ends and without a rain cap moisture can enter the chimney.

1. Fit the cap on to the top chimney length.
2. Screw the stainless steel metal screws supplied with the cap through the pre-punched holes in the bottom of the cap and into the lower length. Be sure to use a metal screw in each pre-punched hole.

After market chimney top devices

It is a common practice for chimneys to be installed with custom made rain caps and terminations of various kinds. This includes such after market devices as Exhausto chimney top fans and chimney top dampers. The following factors must be considered when installing a chimney termination other than our factory-built and listed chimney caps.

When installing a chimney top device of any kind you must deduct the length of chimney equivalent to the weight of the device from the maximum rated capacity. If additional support is required we recommend the use of a roof support as close to the top of the chimney as possible.

We recommend the use of a roof brace or guy wires to provide lateral support when an alternate chimney top is installed. Additional lateral support is not required when the chimney is installed in a chase if the chimney does not project more than 18 inches above the chase top. The use of a roof support is recommended for chase installations.

Model RIS has exposed insulation at the ends. In most installations RIS is terminated with our factory built cap which covers the end of the insulation. When using any other type of cap you must use a factory supplied closure ring (part #RCB) to cover the top of the chimney.

CHIMNEY LENGTHS (RIL)

The Lengths are available in sizes from 6" to 24" I.D. and in lengths of 12", 24" & 48".

The standard materials are:
Casing - Type 304 Stainless Steel
Flue - Type 304 Stainless Steel

Other materials are available on request.

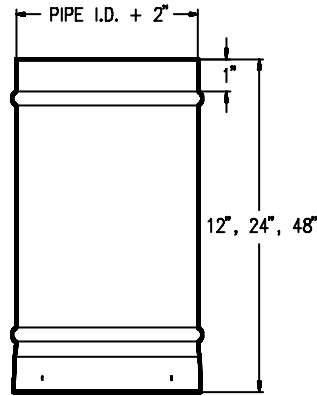

ADJUSTABLE LENGTH (RILA)

There are two Adjustable Lengths available. They can be used between elbows or wherever an odd length is required.

Cat. No.	Length (in)
RILA1	7½" - 12"
RILA2	13½" - 24"

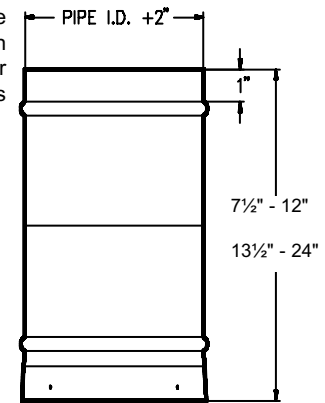

INSULATED TEE (RIT)

Designed to connect horizontal and vertical sections of the chimney.

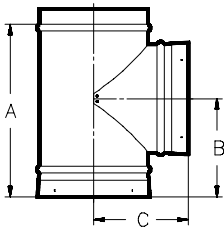

PIPE I.D.	DIM. A	DIM. B	DIM. C
6"	12 3/4"	7"	7"
8"	14 3/4"	8"	8"
10"	16 3/4"	9"	9"
12"	18 3/4"	10"	10"
14"	20 3/4"	11"	11"
16"	22 3/4"	12"	12"
18"	24 3/4"	13"	13"
20"	26 3/4"	14"	14"
22"	28 3/4"	15"	15"
24"	30 3/4"	16"	16"
26"	32 3/4"	17"	17"
28"	34 3/4"	18"	18"
30"	36 3/4"	20"	20"
32"	38 3/4"	21"	21"
34"	40 3/4"	22"	22"
36"	42 3/4"	23"	23"
38"	44 3/4"	24"	24"
40"	46 3/4"	25"	25"
42"	48 3/4"	26"	26"
44"	50 3/4"	27"	27"
46"	52 3/4"	28"	28"
48"	54 3/4"	29"	29"

RADIATION SHIELD (RRS)

Used when the chimney passes through a combustible floor or roof.

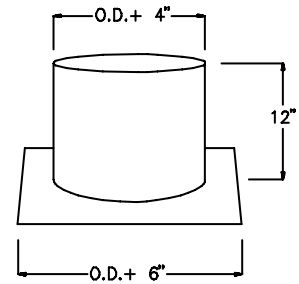

ELBOWS (RIE15, RIE30, RIE45)

Used when a directional change is required. Note: 45° elbows are approved for use in Canada only.

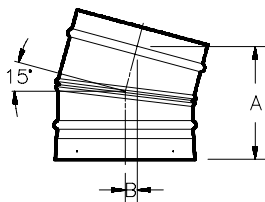

15° ELBOW

I.D.	A	B
6"	5 7/8"	5/8"
8"	6 3/8"	3/4"
10"	6 7/8"	3/4"
12"	7 3/8"	7/8"
14"	7 7/8"	7/8"
16"	8 3/8"	1"
18"	8 7/8"	1"
20"	9 3/8"	1 1/8"
22"	9 7/8"	1 1/8"
24"	10 3/8"	1 1/4"

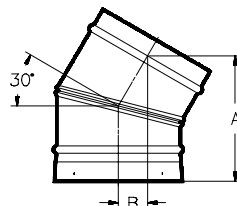

30° ELBOW

I.D.	A	B
6"	7 1/2"	1 5/8"
8"	8"	1 3/4"
10"	8 1/2"	1 7/8"
12"	9"	2"
14"	9 1/2"	2 1/8"
16"	10"	2 1/4"
18"	10 1/2"	2 1/2"
20"	11"	2 5/8"
22"	11 1/2"	2 3/4"
24"	12"	2 7/8"

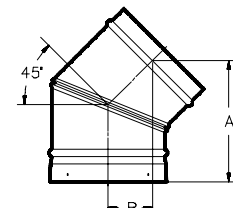

45° ELBOW

I.D.	A	B
6"	7 7/8"	1 7/8"
8"	8 5/8"	2 3/8"
10"	9 3/8"	2 3/4"
12"	10"	3 1/4"
14"	10 3/4"	3 3/4"
16"	11 1/2"	4 1/4"
18"	12 1/4"	4 5/8"
20"	12 7/8"	5 1/8"
22"	13 1/2"	5 5/8"
24"	14 1/4"	6"

FLOOR or BASE SUPPORT (RBS)

Designed to support the chimney from a floor or roof.

It may be used as a supplementary support when the chimney height exceeds that of the primary support.

The support attaches to the chimney casing.

See Support Capacity Table for maximum supported chimney height.

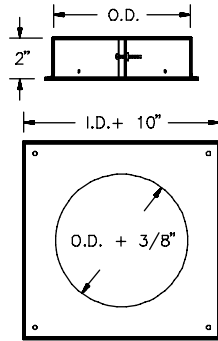

ANCHOR PLATE (RAP)

The anchor plate is used to connect an RIS chimney to a masonry fireplace or to connect an RIS chimney to an existing masonry chimney. The base plate of the anchor plate is made from 10 gauge (1/8") galvanized steel.

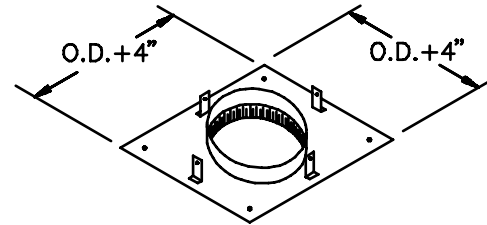

WALL SUPPORT (RWS)

Designed to support a chimney on a wall.

See Support Capacity Table for maximum supported chimney height.

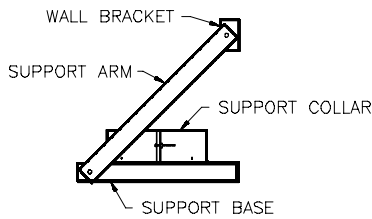

WALL BAND (RWB)

Used on vertical or horizontal runs of chimney to stabilize the chimney.

The recommended maximum distance between Wall Bands is 8'.

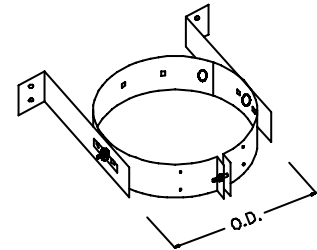

ROOF FLASHING (RF, RFA, RFB)

Used to provide weather protection where the chimney penetrates the roof.

Three models are available to accommodate various roof pitches.

The Storm Collar (SC) is included.

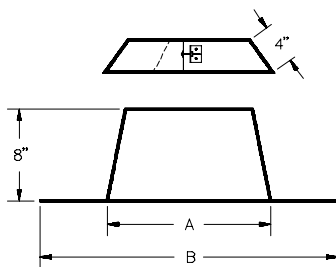

PIPE I.D.	DIM. A	DIM. B
6"	14"	24"
8"	16"	24"
10"	18"	28"
12"	20"	28"
14"	22"	32"
16"	24"	32"
18"	26"	36"
20"	28"	36"
22"	30"	40"
24"	32"	40"

RAIN CAP (RRC & RDC)

The RIS rain cap is constructed entirely of stainless steel. It is designed to provide good protection from wind and rain while incorporating small size and a low profile.

Note: If you intend to use an after market cap with RIS chimney you must terminate the chimney with an ICC Rain Cap Base (part #RCB) The RCB closes off the top of the cap to prevent moisture from entering the chimney.

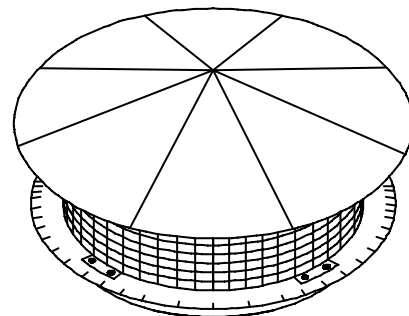

ROOF SUPPORT (RSR)

The roof support is used above an offset, to provide additional support when the chimney height exceeds the primary support capacity, or when it is difficult to install a round or square support.

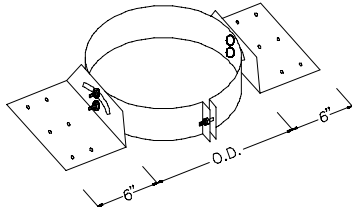

GUY BAND (RGB)

Designed to stabilize the chimney above the roof line.

The maximum un-guyed chimney height above the roof is 5'.

The maximum guyed chimney height above the roof is 20'.

May be used to replace Wall Bands where their installation is difficult.

Uses three wires installed at 120° intervals.

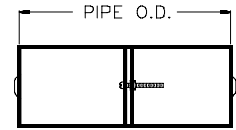

LOCKING BAND (RSLB & RGLB)

All RIS insulated components are designed to be fastened together with the stainless steel screws provided with each part. In some cases, it may be desirable to install a locking band. The locking band is designed to overlap the two beads immediately above and below the chimney joint and fastens with a 1/4" bolt. The locking band does not totally eliminate the requirement for screws.

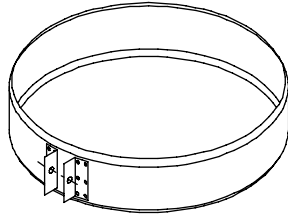

OFFSET SUPPORT (ROS)

The offset support is primarily used to re-support the chimney above an offset, however it may also be used to provide additional support when the chimney height exceeds the capacity of the primary support.

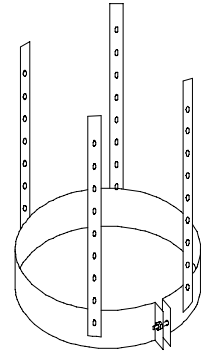

ROOF BRACE (RRB)

Designed to provide a lateral support for the chimney above a roof. The roof brace must be fastened solidly into a structural member.

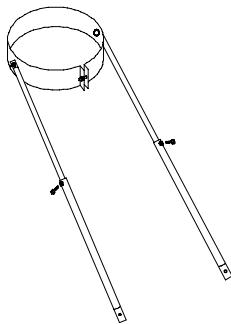

RIS Offset Tables

TABLE 7

TABLE 8

RIS Offset Table 10 to 16 inches						
LENGTH BETWEEN ELBOWS	2 X 15°		2 X 30°		2 X 45°	
	OFFSET	RISE	OFFSET	RISE	OFFSET	RISE
10 INCH Ø						
NO LENGTH	1.57	11.89	3.77	14.09	6.58	15.88
12" Length	4.35	22.28	9.15	23.40	14.18	23.48
24" Length	7.45	33.87	15.15	33.79	22.66	31.96
48" Length	13.67	57.05	27.15	54.58	39.63	48.93
48" + 12"	16.45	67.43	32.52	63.88	47.23	56.53
48" + 24"	19.55	79.03	38.52	74.28	55.72	65.02
48"+24"+12"	22.34	89.41	43.90	83.59	63.32	72.62
48" + 48"	25.77	102.2	50.52	95.06	72.69	81.99
12 INCH Ø						
NO LENGTH	1.57	11.89	4.02	15.02	7.11	17.16
12" Length	4.35	22.28	9.40	24.33	14.71	24.76
24" Length	7.45	33.87	15.40	34.72	23.19	33.24
48" Length	13.67	57.05	27.40	55.51	40.16	50.21
48" + 12"	16.45	67.43	32.77	64.82	47.77	57.82
48" + 24"	19.55	79.03	38.77	75.21	56.25	66.30
48"+24"+12"	22.34	89.41	44.15	84.52	63.85	73.90
48" + 48"	25.77	102.2	50.77	95.99	73.22	83.27
14 INCH Ø						
NO LENGTH	1.70	12.88	4.27	15.95	7.81	18.86
12" Length	4.48	23.26	9.65	25.26	15.41	26.46
24" Length	7.58	34.85	15.65	35.66	23.90	34.95
48" Length	13.80	58.03	27.65	56.44	40.87	51.92
48" + 12"	16.58	68.42	33.02	65.75	48.47	59.52
48" + 24"	19.68	80.01	39.02	76.14	56.96	68.01
48"+24"+12"	22.47	90.39	44.40	85.45	64.56	75.61
48" + 48"	25.89	103.1	51.02	96.63	73.93	84.98
16 INCH Ø						
NO LENGTH	1.70	12.88	4.52	16.89	8.34	20.14
12" Length	4.48	23.26	9.90	26.20	15.95	27.75
24" Length	7.58	34.85	15.90	36.59	24.43	36.23
48" Length	13.80	58.03	27.90	57.37	41.40	53.20
48" + 12"	16.58	68.42	33.27	66.68	49.00	60.80
48" + 24"	19.68	80.01	39.27	77.08	57.49	69.29
48"+24"+12"	22.47	90.39	44.65	86.39	65.09	76.89
48" + 48"	25.89	103.1	51.27	97.86	74.46	86.26

All measurements are in inches

RIS Offset Table 18 to 24 inches						
LENGTH BETWEEN ELBOWS	2 X 15°		2 X 30°		2 X 45°	
	OFFSET	RISE	OFFSET	RISE	OFFSET	RISE
18 INCH Ø						
NO LENGTH	1.82	13.86	4.77	17.82	8.87	21.42
12" Length	4.61	24.24	10.15	27.13	16.48	29.03
24" Length	7.71	35.83	16.15	37.52	24.96	37.51
48" Length	13.92	59.02	28.15	58.31	41.93	54.48
48" + 12"	16.71	69.40	33.52	67.62	49.53	62.08
48" + 24"	19.81	80.99	39.52	78.01	58.02	70.57
48"+24"+12"	22.59	91.38	44.90	87.32	65.62	78.17
48" + 48"	26.02	104.1	51.52	98.79	74.99	87.54
20 INCH Ø						
NO LENGTH	1.82	13.86	5.15	19.22	9.58	23.13
12" Length	4.61	24.24	10.52	28.53	17.18	30.73
24" Length	7.71	35.83	16.52	38.92	25.67	39.22
48" Length	13.92	59.02	28.52	59.71	42.64	56.19
48" + 12"	16.71	69.40	33.90	69.02	50.24	63.79
48" + 24"	19.81	80.99	39.90	79.41	58.73	72.28
48"+24"+12"	22.59	91.38	45.27	88.72	66.33	79.88
48" + 48"	26.02	104.1	51.90	100.1	75.70	89.25
22 INCH Ø						
NO LENGTH	1.95	14.84	5.40	20.15	9.93	23.98
12" Length	4.74	25.23	10.77	29.46	17.54	31.59
24" Length	7.84	36.82	16.77	39.86	26.02	40.07
48" Length	14.05	60.00	28.77	60.64	42.99	57.04
48" + 12"	16.84	70.38	34.15	69.95	50.59	64.64
48" + 24"	19.94	81.97	40.15	80.34	59.08	73.13
48"+24"+12"	22.72	92.36	45.52	89.65	66.68	80.73
48" + 48"	26.15	105.1	52.15	101.1	76.05	90.10
24 INCH Ø						
NO LENGTH	1.95	14.84	5.65	21.09	10.64	25.69
12" Length	4.74	25.23	11.02	30.40	18.24	33.29
24" Length	7.84	36.82	17.02	40.79	26.73	41.78
48" Length	14.05	60.00	29.02	61.57	43.70	58.75
48" + 12"	16.84	70.38	34.40	70.88	51.30	66.35
48" + 24"	19.94	81.97	40.40	81.27	59.79	74.84
48"+24"+12"	22.72	92.36	45.77	90.58	67.39	82.44
48" + 48"	26.15	105.1	52.40	102.0	76.76	91.81

All measurements are in inches

We recommend that our products be installed and serviced by professionals who are certified in the U.S. by NFI (National Fireplace Institute) or in Canada by WETT (Wood Energy Technical Training).



EXCEL AND RIS CHIMNEY LIMITED LIFETIME WARRANTY

Industrial Chimney Company (ICC) warrants its Excel and RIS chimney systems to be free from functional failure due to defects in material or workmanship for as long as the original consumer owns the chimney system. This warranty provides for replacement of any components which fail as a result of normal use on a residential fireplace, wood burning stove, furnace or boiler and includes replacement of any components damaged as a result of a chimney fire. (Note: chimney fires are dangerous and preventable. We strongly encourage you to have your chimney cleaned regularly.) ICC warrants all stainless steel chimney components against perforation as a result of corrosion. This warranty does not cover damage caused to the building by chimney fires or misuse of the product.

No claims under this warranty will be honored unless ICC is notified of the potential claim and is given the opportunity to have one of its agents examine the chimney prior to replacement.

ICC will only be responsible for repair or replacement of any components found to be defective under this warranty. In no event shall ICC be responsible for any incidental or consequential damage caused by defects in the Excel or RIS chimney system.

During the first ten years of the warranty ICC will provide replacement chimney components at no charge. During the balance of the warranty ICC will provide replacement chimney components at 50% of the current retail price at the time of the warranty claim.

ICC will not be responsible for labor of any kind required in the removal or replacement of an Excel or RIS system replaced under this warranty.

These chimneys are designed to vent residential heating oil, untreated wood, low sulphur coal, and natural or LP gas. They are designed to operate at a continuous temperature of 650°C (1200°F) or less. They are not designed to vent condensing oil or gas appliances. This warranty is void if the chimney is used in an application for which it is not designed.

The Excel and RIS systems must be installed according to the Installation Instructions included with every system at the time of purchase. If you do not have a set of installation instructions, they are available free upon request. This warranty is void if the chimney is not installed according to the installation instructions.

This warranty may not be extended or modified by our agents or representatives. This warranty is in lieu of all other express warranties or guarantees, of any kind.

This warranty is effective as of January 1, 2001.